



Electric Double Pallet Stacker

LEDD 12,5/18 IS - LEDD 12,5/20 IS

1,800kg to 2,000kg Capacity

The all new Doosan LEDD Series offers you

**The best solution...
for your material handling!**

Design Features

- Powerful AC drive motor providing high speed for use in warehouses and on ramps
- Low energy consumption and easy maintenance
- Narrow aisle width
- Great manoeuvrability with small turning radius

Operating Elements

- Multifunctional, ergonomical handles
- Turtle mode for precise operations in small areas

Standard Equipment

- AC controlled drive contactorless electronics
- Tandem Vulkollan load wheels
- Large Vulkollan drive tyre

Options

- Various fork dimensions (length and width)
- Cold store model (down to -30°C)
- Multifunctional display
- Stainless steel models for food industry

Made in
Germany



Technical Specifications

Description			LEDD 12,5/18 IS	LEDD 12,5/20 IS
Load capacity	Q	kg	1250/1800	1250/2000
Load centre	c	mm	600	600
Closed height when lowered	h_{13}	mm	90	90
Lift height	h_3	mm	210	210
Handle height of tiller when vertical	h_{14}	mm	1260	1260
Overall length	L	mm	1860	1860
Overall width	B	mm	660	660
Leading structure length	L_2	mm	660	660
Wheel base	y	mm	1510	1510
Load wheel position	RTA	mm	980	980
Fork length	l	mm	1200	1200
Fork width	e	mm	190	190
Dimension across forks	b_5	mm	550	550
Turning Radius	RWa	mm	1670	1670
Empty weight (without battery)	m	kg	570	570
Aisle width (800x1200 lengthwise)	Ast_3	mm	2060	2060
Battery: Capacity		Ah	160-250	160-250
Voltage		V	24	24
Tank LBH 610x200x510..610 mm	24V2EPzH	160..250Ah	•	•
Drive motor output	n/V/kW		1/24/1,0	1/24/1,0
Drive control	Impulse		AC	
Lifting motor output at 15% ED	n/V/kW		1/24/1,4	1/24/1,4

Product and specifications are subject to improvement and change without notice

• = on request

Mast Specifications

Lifting height mm	Closed height mm	Capacity at height kg
1790	1295	1250
1890	1345	1250
2090	1445	1000
2490	1645	700

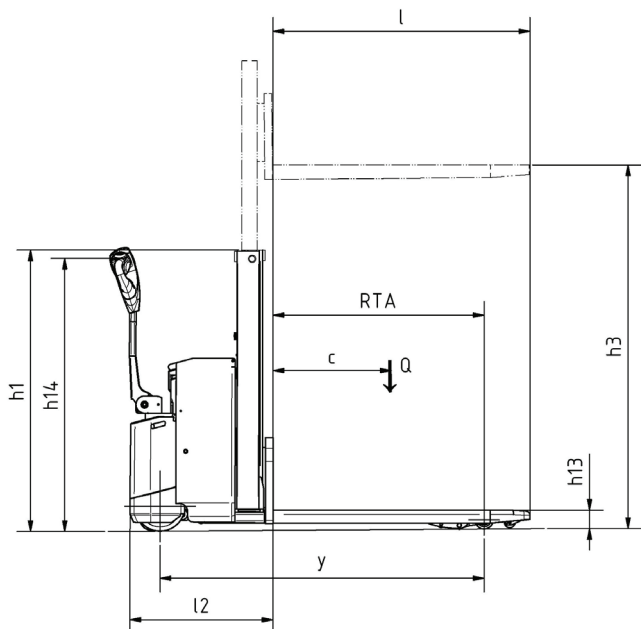
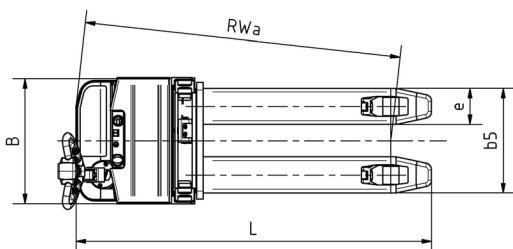

DIEU0811LEDD (Nov.2008)



Doosan Infracore
Forklifts

European Office: Europark Noord 36, 9100 Sint-Niklaas, Belgium
Tel: +3237600987
Fax: +3237600989
Web site: <http://www.doosaneurope.com>



Electric Double Pallet Stacker

LEDD 12,5/18 IS - LEDD 12,5/20 IS

1,800kg to 2,000kg Capacity

The all new Doosan LEDD Series offers you

The best solution...
for your material handling!

Design Features

- Powerful AC drive motor providing high speed for use in warehouses and on ramps
- Low energy consumption and easy maintenance
- Narrow aisle width
- Great manoeuvrability with small turning radius

Operating Elements

- Multifunctional, ergonomical handles
- Turtle mode for precise operations in small areas

Standard Equipment

- AC controlled drive contactorless electronics
- Tandem Vulkollan load wheels
- Large Vulkollan drive tyre

Options

- Various fork dimensions (length and width)
- Cold store model (down to -30°C)
- Multifunctional display
- Stainless steel models for food industry

Made in
Germany



Technical Specifications

Description			LEDD	LEDD
			12,5/18 IS	12,5/20 IS
Load capacity	Q	kg	1250/1800	1250/2000
Load centre	c	mm	600	600
Closed height when lowered	h_{13}	mm	90	90
Lift height	h_3	mm	210	210
Handle height of tiller when vertical	h_{14}	mm	1260	1260
Overall length	L	mm	1860	1860
Overall width	B	mm	660	660
Leading structure length	L_2	mm	660	660
Wheel base	y	mm	1510	1510
Load wheel position	RTA	mm	980	980
Fork length	l	mm	1200	1200
Fork width	e	mm	190	190
Dimension across forks	b_5	mm	550	550
Turning Radius	RWa	mm	1670	1670
Empty weight (without battery)	m	kg	570	570
Aisle width (800x1200 lengthwise)	Ast_3	mm	2060	2060
Battery: Capacity		Ah	160-250	160-250
Voltage		V	24	24
Tank LBH 610x200x510..610 mm	24V2EPzH	160..250Ah	•	•
Drive motor output	n/V/kW		1/24/1,0	1/24/1,4
Drive control	Impulse		AC / (DC •)	
Lifting motor output at 15% ED	n/V/kW		1/24/2,2	1/24/2,2

Product and specifications are subject to improvement and change without notice

• = on request

Mast Specifications

Lifting height mm	Closed height mm	Capacity at height kg
1690	1245	1250
1790	1295	1250
1890	1345	1250
1990	1395	800
2090	1445	700

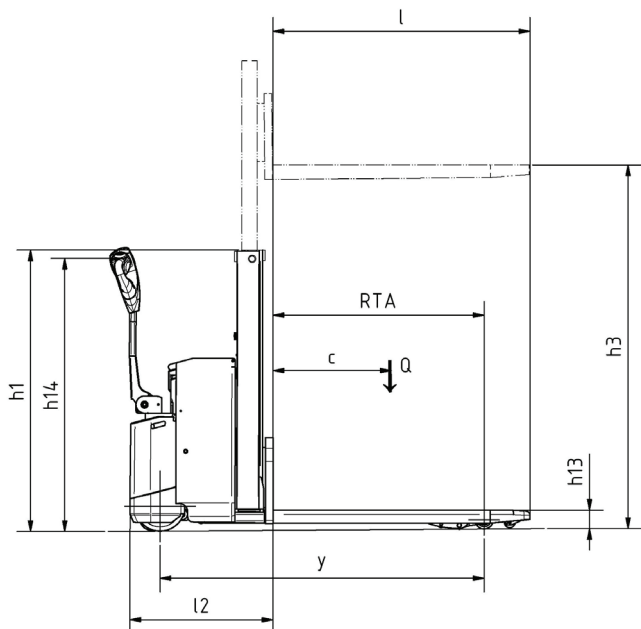
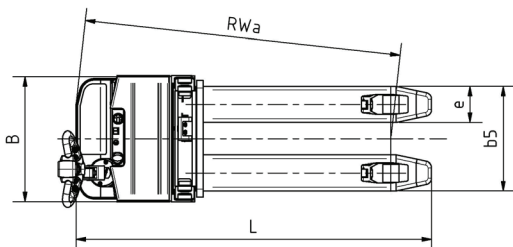

DIEU0811LEDD (Nov.2008)



Doosan Infracore
Forklifts

European Office: Europark Noord 36, 9100 Sint-Niklaas, Belgium
Tel: +3237600987
Fax: +3237600989
Web site: <http://www.doosaneurope.com>